

Water cooled water chillers

WHZ 024.2÷047.2

Cooling capacity from 85 to 164 kW

50 Hz - refrigerant: HFC 407 C

HFC 407C

ECOLOGICAL REFRIGERANT



McQuay is participating in the Eurovent Certification Programme. Product are as listed in the Eurovent Directory of Certified Products and on the web site www.eurovent-certification.com



McQuay[®]
Air Conditioning

McQuay water cooled water chiller

McQuay Int'l introduces their newest water cooled water chiller type WHZ equipped with Scroll compressors and electronic control system. McQuay have once again succeeded in developing a high quality product with extraordinary performance which is able to satisfy HVAC application, industrial refrigeration an icestore application. For more than 60 years, McQuay have designed and built successful line of products. The latest technology is included in the new WHZ chiller range equipped with Scroll compressor and unsurpassed advanced features. All units are equipped with electronic control device control which optimises the unit operation also improving the interface with devices for remote monitoring.

Low operating costs

The McQuay WHZ chillers use the most reliable and efficient components in the industry. Scroll compressors offer an operating economy that at partial load conditions is uncomparable with the most aggressive competitors. The unloading system with multiple capacity steps reduce allows the electrical consumption to the plant requirement. The use of a single evaporator provided with multiple refrigerant circuits improves the unit performance at partial load operation.

Low installation costs

All units are completely factory assembled. A rigid steel base with lifting points permits quick unit rigging. Power and control panel mounted on the shorter side of the unit determines a more optimized location of unit inside the chillers room, allowing easy maintenance and control. WHZ units are fully wired and supplied with a single power connection. Extensive quality control operation tests assure trouble-free installation and start-up.

Full factory testing

Pressure vessels tests are performed on all units then evacuated and charged with refrigerant HFC 407C. All safety and operating controls are properly checked and calibrated at the factory. A complete performance test simulates the given conditions. A second series of tests may also be performed at customer's presence. Before shipment, each unit is re-checked for pressure and refrigerant charge control.

Code requirements

WHZ units can be manufactured and certified in accordance with PED code requirements.

Reliability

The use of scroll compressors together with the most advanced and efficient control system assures reliable functioning. Each refrigerant circuit comes complete with multiple safety devices which prevent compressor damage.

Serviceability

All multiple compressor units use independent refrigerant circuits. They permit shut-down, routine maintenance and service of one of the circuit while the others maintain the system operation.

Programmable electronic control device

The control device is installed as standard on all water cooled chiller series WHZ. It visualises all operating values and setpoint recorded allowing setting and modifying the regulation parameters at a later stage. An infrared remote

control and a serial output board are available as option for a supervisor connection.

General characteristics

Structure

The chiller is equipped with brackets directly installed on heat exchangers. The evaporator and the suction piping are appropriately insulated to prevent condensation.

Scroll Compressors

Compressors: unit model WHZ 024.2 is equipped with two single compressors, unit model WHZ 032.2 047.2 install two tandem scroll hermetic compressors. Electric motors are DOL starting type.

Evaporator

The evaporator is a direct expansion shell-and-tube type constructed with a carbon steel shell and seamless high efficiency copper tubes. It is equipped with a baffled shell side to ensure the appropriate water flowing outside the tubes obtaining the maximum heat exchange with the lowest pressure drop. Externally the shell is protected by 10 mm thickness closed-cell insulation material. Evaporator water connections of victaulic type are equipped with a water nozzle to be welded on the plant piping system.

Condensers

Condensers are shell and cleanable, through-tube type. The unit has independent condensers, one per circuit. Each condenser has a carbon steel and seamless, integrally finned high efficiency copper tubes, roll expanded into heavy carbon steel tube sheets. Water heads are removable and include vent and drain plugs. Condensers come complete with liquid shut-off valve, spring loaded relief valve.

Refrigerant circuits

Each refrigerant circuit is completely independent and complete with all control and regulation devices such as: filter driers, liquid sight glass and thermostatic expansion valves.

Power and starting panel

Inside the electrical panel is installed a programmable electronic control, including temperature sensors, keypad to set and control data protected by a password. All devices are factory installed and wired. The unit controls are designed to allow the reading and the updating of data both locally and remotely.

Available versions

Water chiller model WHZ is available in three versions:

WHZ ST — Standard version equipped with water cooled condensers

WHZ LR — Special execution without the water cooled condensers. The units suitable for remote condenser operation are equipped with liquid receivers, one per circuit and with copper tube connection.

WHZ ME — Special execution as the previous version but also without the liquid receivers to be arranged on the installation.

Accessories and options

01 - 100% total heat recovery (R) produced with tube bundle placed in a single shell with the water condensers. Heat exchangers heads are provided with 2 connections for entering/leaving heat recovery water and 2 separate connections for condensing water.

11 - Compressor thermal relays. Safety device against compressor motor overloading.

42 - Flow switch. For field installation on evaporator and condensers pipes to prevent freeze up under low temperature conditions. It must be wired to the power panel terminals by the customer.

84 - Rubber antivibration isolators. They are available for field installation to reduce vibrations transmission through the unit base.

86 - Sound proof jacket on compressors. Made of insulated material to reduce the sound noise level of the compressors (-3 dBA).

Table 1 – Operatine limits

		HFC 407C
Maximum evap. entering water temp. (without glycol)	°C	24
Maximum evap. leaving water temp. (without glycol)	°C	16
Minimum evap. leaving water temp. (with glycol)	°C	-8
Maximum cond. leaving water temp.	°C	50
Minimum cond. leaving water temp.	°C	30

Note: Table 1 is referred to 2 passes condenser.

Table 2 – Evaporator fouling factors

Fouling factor m ² °C / kW	Cooling capacity correction factor	Power input correction factor	COP correction factor
0,0440	1,000	1,000	1,000
0,0880	0,986	0,992	0,994
0,1320	0,972	0,984	0,987

Table 3 – Condenser fouling factors

Fouling factor m ² °C / kW	Cooling capacity correction factor	Power input correction factor	COP correction factor
0,0440	1,000	1,000	1,000
0,0880	0,990	1,018	0,973
0,1320	0,981	1,036	0,945

Table 4 – Ethylene glycol correction factors

Air ambient temperature °C	-3	-8	-14	-22	-33
Ethylene glycol %	10	20	30	40	50
Cooling capacity correction factor	0,991	0,985	0,972	0,961	0,946
Power input correction factor	0,996	0,992	0,986	0,976	0,966
Water flow rate correction factor	1,013	1,040	1,074	1,121	1,178
Water pressure drop correction factor	1,070	1,129	1,181	1,263	1,308

Table 5 – Brine application correction factors

Glicol/water leaving temperature °C	2	0	-2	-4	-6	-8
Min. % of ethylene glycol	10	20	20	30	30	30
Cooling capacity correction factor *	0,840	0,782	0,726	0,673	0,623	0,575
Power input correction factor *	0,950	0,940	0,920	0,890	0,870	0,840

* Correction factors have to be applied to performance data at the requested condenser outlet water temperature and 7°C leaving water temperature

Sound pressare level

Size	Sound pressure level at 1 m from unit in free field (rif. 2 x 10 ⁻⁵)								
standard WHZ	63 Hz	125 Hz	250 Hz	500 Hz	1000 Hz	2000 Hz	4000 Hz	8000 Hz	dBA
024.2	63,0	55,5	63,5	75,0	72,5	69,5	68,0	58,5	77,0
032.2	64,0	56,5	64,5	76,0	73,5	70,5	69,0	59,5	78,0
041.2	64,0	56,5	64,5	76,0	73,5	70,5	69,0	59,5	78,0
047.2	64,0	56,5	64,5	76,0	73,5	70,5	69,0	59,5	78,0
WHZ with sound-proof jacket	63 Hz	125 Hz	250 Hz	500 Hz	1000 Hz	2000 Hz	4000 Hz	8000 Hz	DBA
024.2	62,5	55,0	62,0	74,0	68,5	64,5	62,5	53,0	74,0
032.2	63,5	56,0	63,0	75,0	69,5	65,5	63,5	54,0	75,0
041.2	63,5	56,0	63,0	75,0	69,5	65,5	63,5	54,0	75,0
047.2	63,5	56,0	63,0	75,0	69,5	65,5	63,5	54,0	75,0

Note: Average sound pressure level rated in accordance to ISO 3744, free field conditions.

Physical data WHZ 024.2÷047.2 (HFC 407C)

"WHZ" unit size		024.2	032.2	041.2	047.2
Cooling capacity (1)	kW	84,6	108,9	142,5	165,7
Power input (1)	kW	22,1	28,2	37,5	45,6
Compressors number		2	2 tandem	2 tandem	2 tandem
Compressor model		Scroll	Scroll	Scroll	Scroll
Reduction steps number		2	4	4	4
Refrigerant circuits number		2	2	2	2
Evaporators number		1	1	1	1
Maximum evaporator water pressure	bar	16	16	16	16
Ev. Victaulic water connections diam.		88,9	88,9	88,9	88,9
Condenser N°/passes N°		2/2	2/2	2/2	2/2
Maximum condenser water pressure	bar	16	16	16	16
2 passes cond. water connections		Female 2" GAS			
Unit length (2 passes)	mm	1838	2715	2715	2715
Unit width	mm	600	600	600	600
Unit height	mm	1555	1555	1555	1555
Shipping weight	kg	515	860	860	860
Operating weight	kg	560	900	900	900

Note: (1) Nominal cooling capacity are based on: 12/7°C entering/leaving evaporator water temperature; 30/35°C entering/leaving condenser water temperature.

Electrical data

"WHZ" unit size		024.2	032.2	041.2	047.2
Standard voltage supply		400 V – 3f – 50 Hz (1)			
Max. #1 comp. absorbed current	A	35	50	70	70
Max. #2 comp. absorbed current	A	35	50	70	70
Max. unit absorbed current	A	70	100	140	140
Max. compressor inrush current	A	175	120	175	175
Max. unit inrush current	A	210	195	280	280

Notes: Unbalance between phase $\pm 3\%$; allowable voltage tolerance $\pm 10\%$.

Standard ratings WHZ 024.2 ÷ 047.2 (HFC 407C)

Unit size	Evap. leaving water temp. (°C)	CONDENSER ENTERING WATER TEMPERATURE - °C									
		25		30		35		40		45	
		C.C. (kW)	P.I. (kW)	C.C. (kW)	P.I. (kW)	C.C. (kW)	P.I. (kW)	C.C. (kW)	P.I. (kW)	C.C. (kW)	P.I. (kW)
024.2	4	80,8	19,6	77,3	21,7	73,5	24,2	69,4	27,0	64,9	30,2
	5	83,3	19,7	79,7	21,8	75,8	24,4	71,6	27,1	67,0	30,3
	6	85,8	19,8	82,1	22,0	78,2	24,5	73,8	27,3	69,1	30,5
	7	88,4	19,9	84,6	22,1	80,5	24,7	76,1	27,5	71,3	30,7
	8	91,0	20,1	87,1	22,3	83,0	24,8	78,4	27,6	73,5	30,9
	9	93,6	20,2	89,7	22,4	85,4	25,0	80,7	27,8	75,7	31,0
	10	96,3	20,3	92,3	22,5	87,9	25,2	83,1	28,1	77,9	31,2
	11	99,0	20,4	94,9	22,7	90,4	25,3	85,5	28,2	80,2	31,4
	12	101,7	20,6	97,5	22,8	92,9	25,5	88,0	28,4	82,5	31,6
	13	104,4	20,7	100,2	23,0	95,5	25,6	90,4	28,6	84,9	31,8
	14	107,2	20,8	102,8	23,1	98,1	25,8	92,9	28,8	87,3	32,0
	15	110,1	21,0	105,6	23,3	100,8	26,0	95,4	29,0	89,7	32,3
	16	112,9	21,1	108,3	23,4	103,3	26,1	98,0	29,1	92,1	32,5
032.2	4	103,9	24,9	99,5	27,8	94,6	31,2	89,2	35,0	83,2	39,5
	5	107,1	25,0	102,6	28,0	97,6	31,4	92,1	35,2	86,0	39,7
	6	110,3	25,1	105,7	28,1	100,6	31,5	95,0	35,5	88,8	39,8
	7	113,6	25,3	108,9	28,2	103,7	31,7	98,0	35,6	91,6	40,0
	8	117,0	25,4	112,2	28,4	106,9	31,8	101,0	35,8	94,5	40,3
	9	120,4	25,5	115,5	28,5	110,0	32,0	104,0	36,0	97,4	40,5
	10	123,8	25,6	118,8	28,7	113,3	32,2	107,1	36,1	100,3	40,7
	11	127,3	25,8	122,2	28,8	116,5	32,3	110,2	36,3	103,3	40,9
	12	130,9	25,9	125,6	29,0	119,8	32,5	113,4	36,5	106,4	41,1
	13	134,4	26,1	129,1	29,1	123,2	32,6	116,6	36,7	109,4	41,2
	14	138,1	26,3	132,6	29,3	126,5	32,8	119,9	36,9	112,5	41,4
	15	141,6	26,4	136,1	29,4	130,0	33,0	123,1	37,0	115,7	41,6
	16	145,3	26,5	139,7	29,6	133,4	33,1	126,5	37,2	118,8	41,8
041.2	4	135,7	33,3	130,1	36,9	124,1	41,0	117,5	45,5	110,3	50,5
	5	139,9	33,5	134,2	37,1	128,0	41,2	121,3	45,7	113,9	50,7
	6	144,1	33,7	138,3	37,4	132,0	41,4	125,1	46,0	117,6	51,0
	7	148,5	33,9	142,5	37,5	136,0	41,7	129,0	46,2	121,2	51,3
	8	152,9	34,1	146,8	37,8	140,1	41,9	132,9	46,5	125,0	51,5
	9	157,4	34,3	151,2	38,0	144,3	42,1	136,9	46,7	128,8	51,8
	10	161,9	34,5	155,5	38,2	148,5	42,4	140,9	47,0	132,6	52,1
	11	166,5	34,7	160,0	38,4	152,9	42,6	145,0	47,2	136,6	52,3
	12	171,1	34,9	164,5	38,7	157,2	42,8	149,2	47,5	140,5	52,7
	13	175,8	35,1	169,0	38,9	161,6	43,1	153,4	47,7	144,5	53,0
	14	180,6	35,3	173,6	39,1	166,0	43,3	157,7	48,0	148,6	53,3
	15	185,4	35,5	187,3	39,3	170,5	43,6	162,0	48,4	152,8	53,5
	16	190,2	35,8	183,0	39,6	175,0	43,8	166,4	48,6	157,0	53,8
047.2	4	158,3	40,2	151,5	44,7	144,2	49,9	136,1	55,7	127,5	62,2
	5	163,1	40,5	156,2	45,0	148,7	50,2	140,5	56,1	131,6	62,5
	6	168,0	40,7	161,0	45,4	153,2	50,5	144,8	56,4	135,7	62,9
	7	173,0	40,9	165,7	45,6	157,9	50,9	149,3	56,7	139,9	63,3
	8	178,1	41,2	170,7	45,9	162,6	51,2	153,8	57,0	144,2	63,7
	9	183,1	41,4	175,6	46,2	167,4	51,5	158,4	57,3	148,6	64,0
	10	188,4	41,7	180,6	46,4	172,2	51,8	162,9	57,7	152,9	64,4
	11	193,6	42,0	185,7	46,7	177,1	52,1	167,7	58,1	157,4	64,7
	12	198,9	42,3	190,8	47,0	182,0	52,5	172,4	58,5	161,9	65,2
	13	204,3	42,6	196,0	47,4	187,1	52,8	177,2	58,8	166,4	65,6
	14	209,8	42,8	201,3	47,7	192,1	53,1	182,0	59,1	171,1	65,9
	15	215,2	43,1	206,6	48,0	197,2	53,4	187,0	59,6	175,7	66,3
	16	220,8	43,4	212,0	48,3	202,4	53,7	191,9	59,9	180,5	66,8

Note: ratings are based on evaporator and condenser fouling factor of 0.044 (m²°C/kW) and evaporator and condenser temperature ΔT of 5°C.

Water pressare drop

evaporator

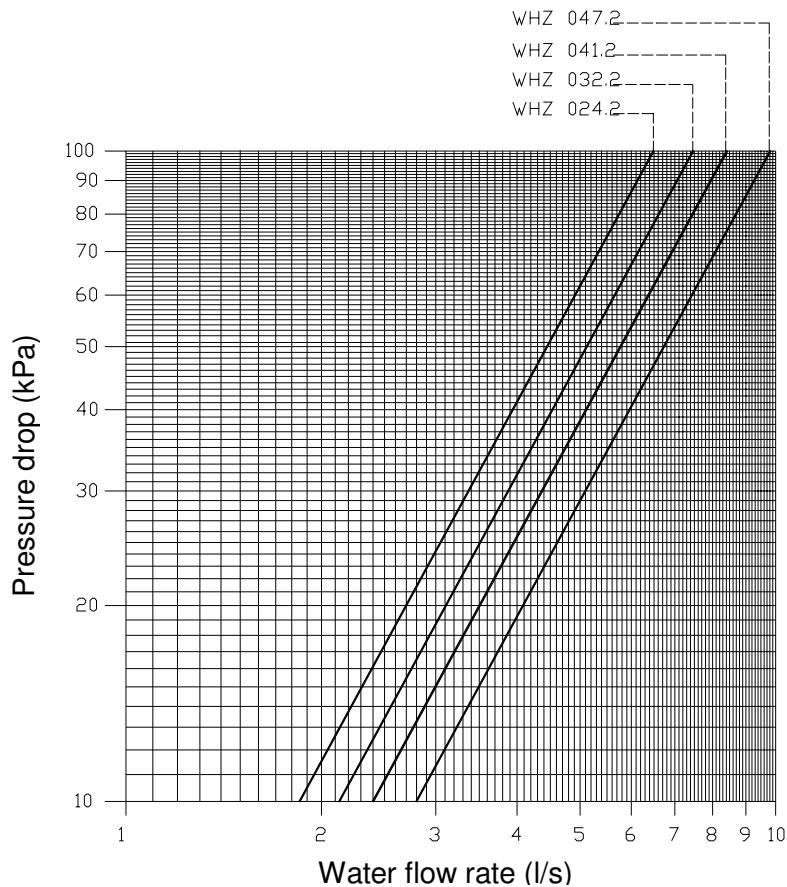

Water pressare drop

2 passes condenser

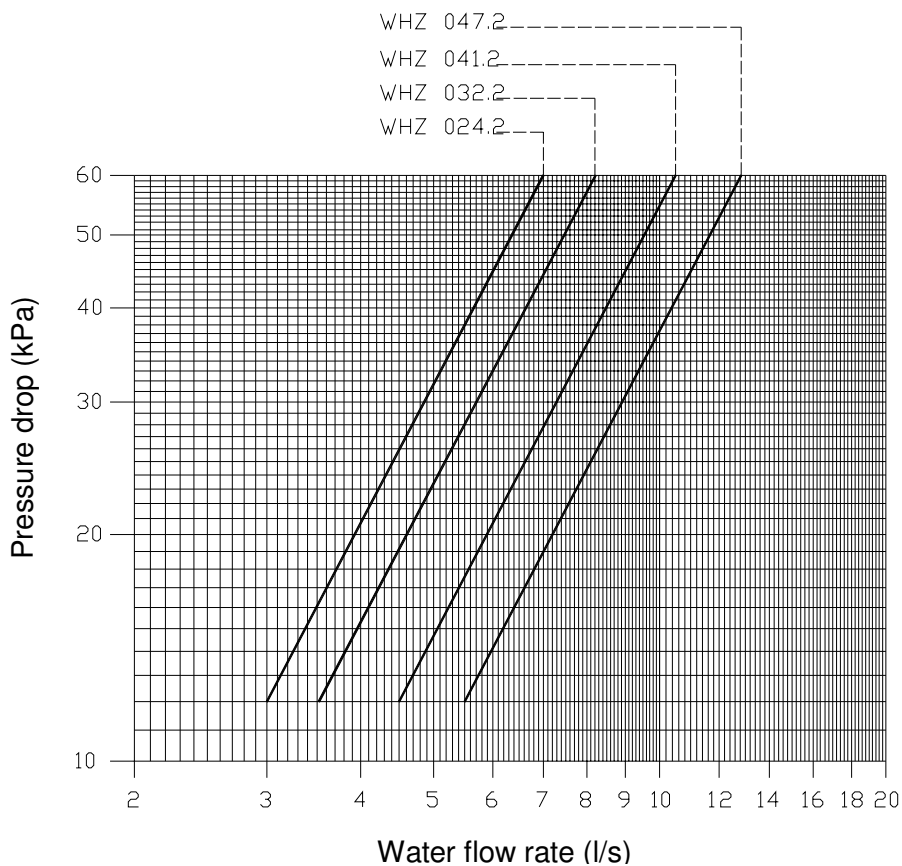

WHZ 024.2 dimensions

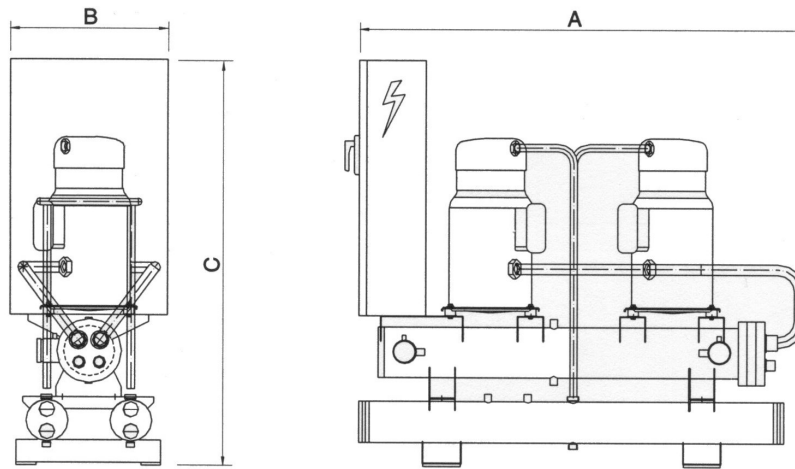

WHZ unit size	Dimensions (mm)		
	A	B	C
024.2	1838	600	1555
032.2	2715	600	1555
041.2	2715	600	1555
047.2	2715	600	1555

WHZ 032.2÷047.2 dimensions

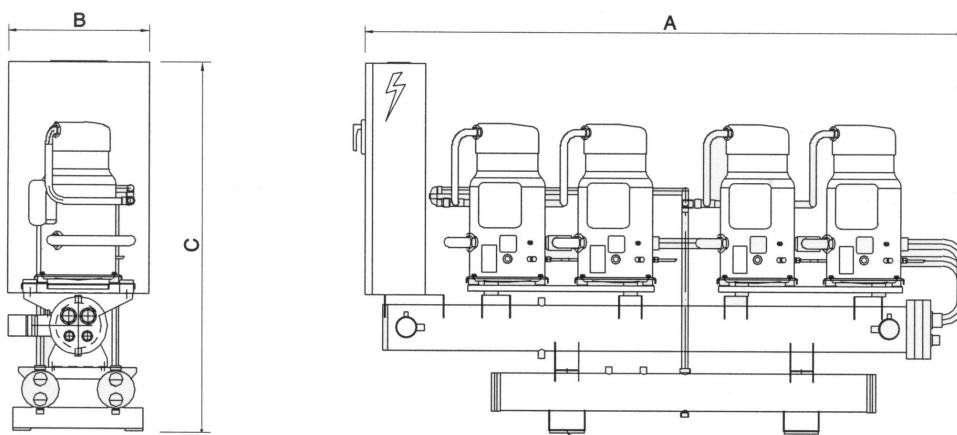

We reserve the right to make changes in design and construction at any time without notice, thus the cover picture is not binding.

McQuay partecipa al programma di
Certificazione Eurovent.
I prodotti interessati figurano nella Guida
Eurovent dei Prodotti Certificati.



McQuay is participating in the Eurovent
Certification Programme
Product are as listed in the Eurovent
Directory of Certified Products

McQuay[®]
International

McQuay Italia S.P.A.

S.S. Nettunense, km 12+300 – 00040 Cecchina (Roma) Italia – Tel. (06) 937311 – Fax (06) 9374014 – E-mail: info@mcquayeuropa.com
www.mcquayeuropa.com